



New Features in BioStar 2.4.1

*May 2017
Ethan Kim*

SUPrema

Contents

Introduction

AC Features

T&A Features

Mobile Application

FaceStation 2

Online Resources / Q&A

DISCLAIMER

This presentation contains information that is confidential and proprietary to Suprema Inc. and is solely for the use of Suprema Inc. personnel. No part of it may be used, circulated, quoted, or reproduced for distribution outside Suprema Inc. If you are not the intended recipient of this report, you are hereby notified that the use, circulation, quoting, or reproducing of this report is strictly prohibited and may be unlawful. No representations or warranties, express or implied, are made as to, and no reliance should be placed on, the accuracy, fairness or completeness of the information presented or contained in this presentation. © 2016 Suprema Inc. All rights reserved

Introduction

BIOSTAR 2.4.1

AC Features

- *Performance increase*
- *MS SQL*

T&A Features

- *Combined Report*
- *Report editing*
- *Leave*
- *Real Time Report*

Mobile Application

- *Mobile Credential Card*
- *Smart Card / FaceStation 2*
- *Biomini / Biomini Plus 2*

FaceStation 2

- *Design*
- *Features*
- *User Interface*
- *Specification*

AC Features

AC Module

** Applies to Maria DB Only*

X 3~9



Device Read

X 3~10



Device Update

X 3~15

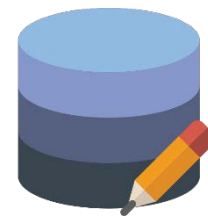

Edit User + Sync

Bottleneck removed

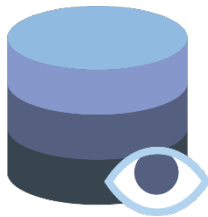

Real-time Monitoring

X 6



Event Log

** Upgrade Caution: you must remember your Maria DB root password*

AC Features

MS SQL 2012 Database

For new installations only

- * *Upgrade from previous version Maria DB to 2.4.1 MS SQL unsupported*
- *Choose Custom Installation*
- *Sa (system admin) account password must be known*
- *Database must be created before installation*

A screenshot of the "Setup - BioStar 2(x64)" window, specifically the "Custom installation" step. The window title bar shows "Setup - BioStar 2(x64)" and standard Windows window controls. The main content area has a heading "Custom installation" and a sub-heading "If you choose database type, you must enter the Root privilege account information for both AC user and TA user." Below this, there are several input fields: "Database Type" (a dropdown menu set to "MS-SQL"), "Server IP", "Server port", "AC DB name", "AC Username", "AC Password", "TA DB name", "TA Username", and "TA Password". There are also two checked checkboxes: "Check the database connection" and "Generate the database tables". At the bottom of the window, there are three buttons: "< Back", "Next >", and "Cancel".

T&A Features

Combined Report

- Time card is included into the Report menu
- Filter based Report Type (previously buttons)
- Customizable / stored report filters

The screenshot displays the T&A system interface. On the left, a sidebar menu includes 'Shift', 'Schedule', and 'Report' (highlighted with a yellow box). Below these are various report options: 'Daily Report', 'Daily Summary Report', 'Individual Report', 'Individual Summary Re...', 'Leave Report', 'Exception Report', and 'Edit History Report'. The 'Report' menu is expanded, showing a list of report types. The 'Search Conditions' panel on the right contains the following fields and controls:

- Name:** Daily Report
- Period:** Monthly (2017-04-01 ~ 2017-04-30)
- Report Type:** Daily Summary (highlighted with a yellow box) and a 'Column Setting' button.
- User Group:** [Search icon]
- User:** 1111(Ethan) [Search icon]
- Rebuild Time Card
- Buttons:** Save Filter, Update Report, CSV Export, PDF Export

T&A Features

Report Editing

- Temporary Schedule, punch log, leave edit all in one page
- No need to switch around Timecard / Schedule

Edit Temporary Schedule

Edit Punch Log

Edit Leave

Date	Shift	Time code	In	Out	Exception	Regular	Overtime
2017/04/07(Fri)	Normal Fix...	Normal Pay	-	-	Absence	0:00:00	0:00:00

Summary	Regular ...	Overtim...	Break Ti...	Over Bre...	Meal Tim...	Exception	Leave	Total Wor...
Daily	0:00:00	0:00:00	0:00:00	0:00:00	0:00:00	1	0	0:00:00

Overtime Rule	Regular By Time Rate	Overtime By Time Rate	Work time in Leave	Non-work time in Lea...
-	0:00:00	0:00:00	0:00:00	0:00:00

T&A Features

Leave

- Leave configurable on a day applied with temporary schedule
- Leave time configurable (half-days)
- Bug fix: absence applied on a flexible shift also applied to fixed shift when the flexible shift day comes after a fixed shift

12

8:00:00 (12:00:00 ~ 18:00:0...
9:00:00 (Normal Fixed Shift)
8:00:00
0:00:00
Paid Leave

Edit Leave ✕

Sam(2222)

Date	2017-04-12(Wed)
Leave	Paid Leave
Use Time	<input checked="" type="checkbox"/>
Start Datetime	2017-04-12 09:00
End Datetime	2017-04-12 13:00
Leave Hours	04:00
Apply to Other User(s)	<input type="text"/>
Approver Comments	Paid half day leave

T&A Features

Real-time T&A Report

- *Rebuild Time Card + Update Report to get current result*
- *Previously report could only be calculated 24 hours after day start time*

Rebuild Time Card

Save Filter **Update Report** CSV Export PDF Export

Daily Report

1 / 1 50 rows ▼

Date	Name	User ID	Depart...	Shift	Leave	In	Out	Exception	Regula...	Overtim...	Total W...
2017/04/...	Ethan	1111	Tech Sup...	Normal F...	-	2017/04/13 14:49:00	2017/04/13 14:57:59	Insufficient work time	0:08:59	0:00:00	0:08:59

Mobile Application

Biomini / Biomini Plus 2 Support

- Use an OTG Cable to connect to an Android phone
- * *Biomini Plus 2 cannot be used with BioStar 2 + PC*



Mobile Application

Smart Card / Face Registration Support

- Register user smart cards by activating devices with mobile app
- Register Face by activating FaceStation 2 with app

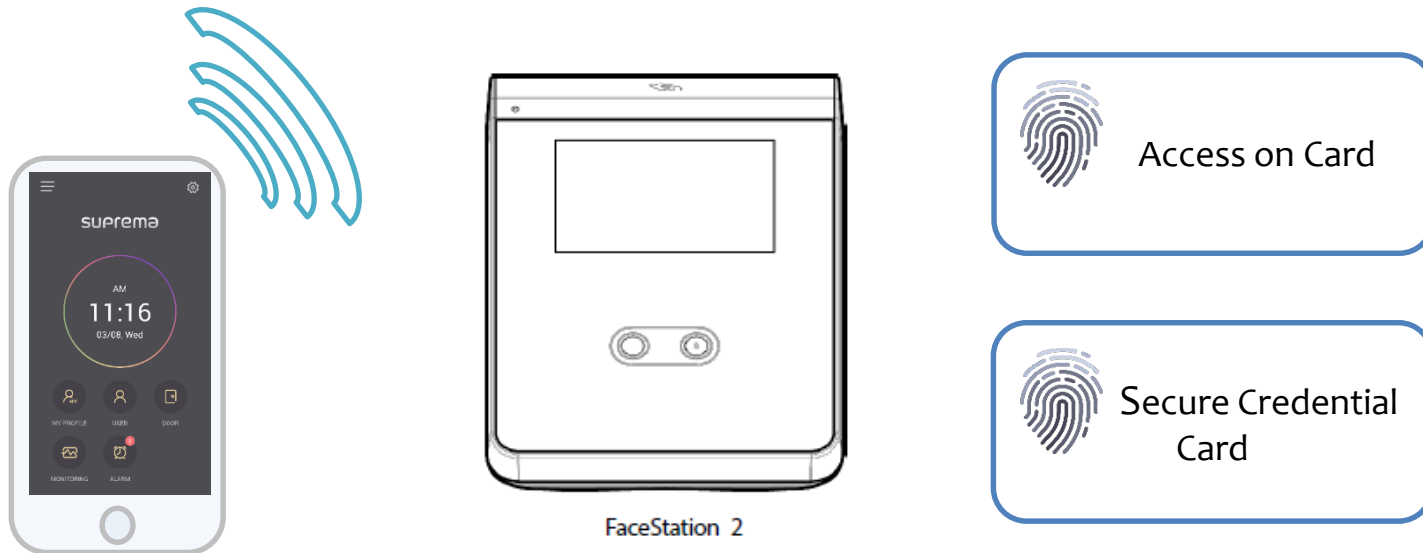

Mobile Application

Mobile Smart Card

- Use your phone like a smart card
- NFC supported devices work with Android
- BLE supported devices work with iOS

* Currently only FaceStation 2

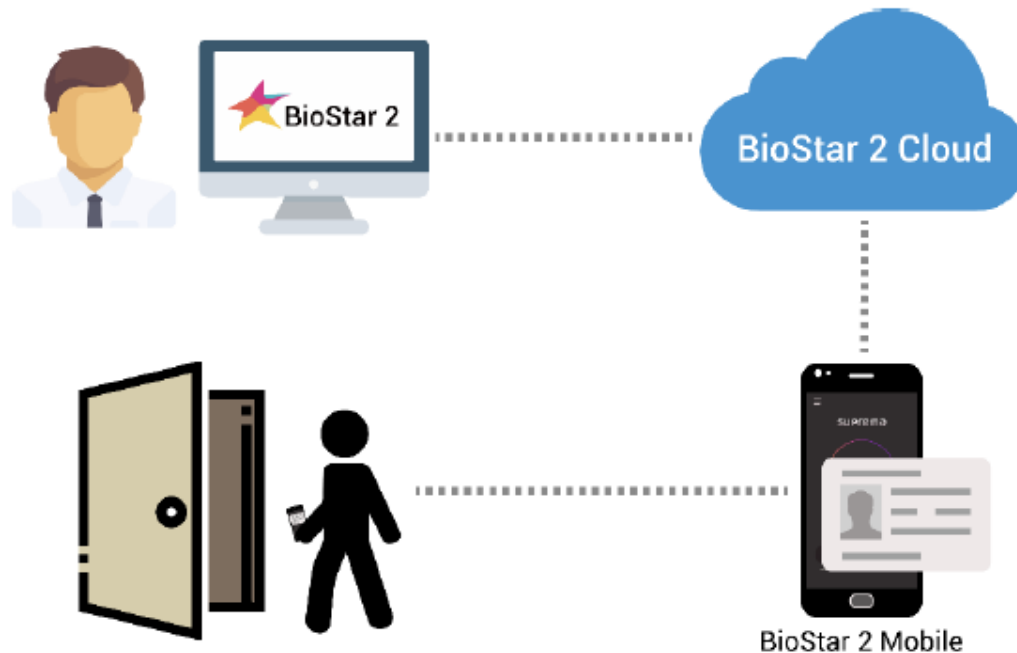

Mobile Application

Mobile Smart Card Demo

The screenshot displays the BioStar 2 mobile application interface. At the top left, the text "BioStar 2" is visible. To its right are navigation icons for "Setting", "About", and "Help". At the top right, the user is identified as "Administrator (Right Third)" with a "Logout" button. A vertical sidebar on the left contains icons for "DASH BOARD", "USER", "DEVICE", "DOOR", "ELEVATOR", "ZONE", "ACCESS CONTROL", "MONITORING", and "TIME ATTENDANCE". The main content area is titled "Setting" and contains a grid of 12 settings cards, each with an icon and a label: ACCOUNT, PREFERENCE, CARD, CARD FORMAT, SERVER, TRIGGER & ACTION, SCHEDULE, ALERT, CLOUD, IMAGE LOG, USB AGENT, and FACE GROUP MATCHING.

BioStar 2 Setting About Help

Administrator (Right Third) Logout

Setting

- ACCOUNT
- PREFERENCE
- CARD
- CARD FORMAT
- SERVER
- TRIGGER & ACTION
- SCHEDULE
- ALERT
- CLOUD
- IMAGE LOG
- USB AGENT
- FACE GROUP MATCHING

FaceStation 2



FaceStation 2

Design

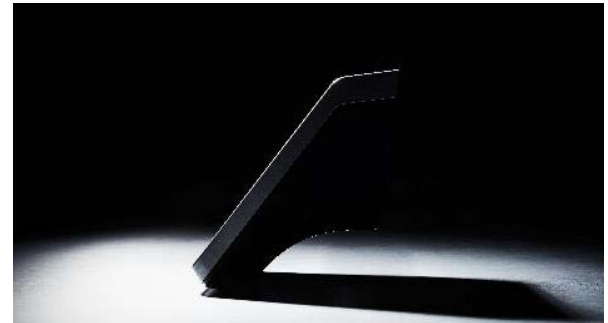

FaceStation 2

Design



141mm

132mm



FaceStation2

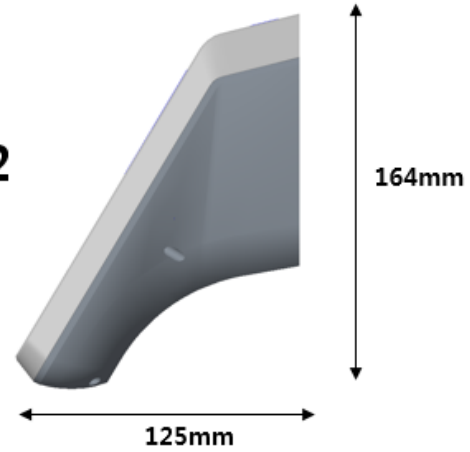

164mm

125mm

60mm

FaceStation



165mm

Design

Improved Ergonomics for Greater Height Range

FaceStation 2 allows the greatest height range of 145cm ~ 210cm. With optional tilt-bracket, FaceStation 2 also accommodate wheelchair persons and children.

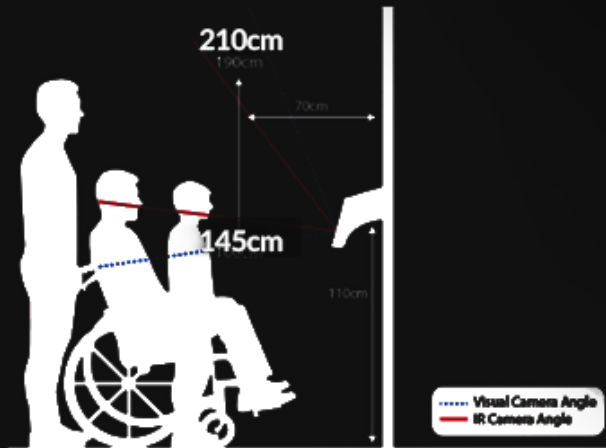

FaceStation 2

Features

Massive Memory Capacity

FaceStation 2 offers a massive memory capacity to manage largest number of users in its class. A single unit of FaceStation 2 can accommodate up to 30,000 users, 50,000 face image logs and 5,000,000 text logs.

30,000
USERS
*1:1 matching

50,000
IMAGE LOGS

5,000,000
TEXT LOGS

3000 1:n matching

5000 Group Matching



FaceStation 2

Features : Group Matching

- Setting > Face Group Matching

← Face Group Matching

General

- Group Matching Use
- Group Matching Device Settings
- Matching Group Settings

Device ID	Device Name	Device Group	IP Address	
13	FaceStation 2 13 (192.168.14.217)	All Devices	192.168.14.217	

+ Add

Order	Group Name	User Group	Number of Faces	
1 ▼	Business Group	Business Team ▼	0 / 3000	
2 ▼	Marketing Group	Marketing Team ▼	0 / 3000	
3 ▼	Technical Group	TS Team (1) ▲	1 / 3000	

+ Add

- Business Team (😊 0)
- Marketing Team (😊 0)
- R&D (😊 0)
- TS Team (😊 1)

Cancel

FaceStation 2

Features

All Lighting Conditions Confidence

With Suprema's patented IR illumination and optical technique, FaceStation 2 now achieves operating illuminance of up to 25,000 lx, about 5 times brighter than industry average. At 25,000 lx, FaceStation 2 allows uninterrupted face recognition regardless of all possible indoor lighting conditions as well as outdoor installations unless exposed on direct sunlight.

0 lx to 25,000 lx
OPERATING ILLUMINANCE



FaceStation 2

Features



*Replicating 25,000 lux brightness
- SGPP 2016*

FaceStation 2

Features



*Replicating 25,000 lux brightness
- SGPP 2016*

Features

Enhanced Security Features

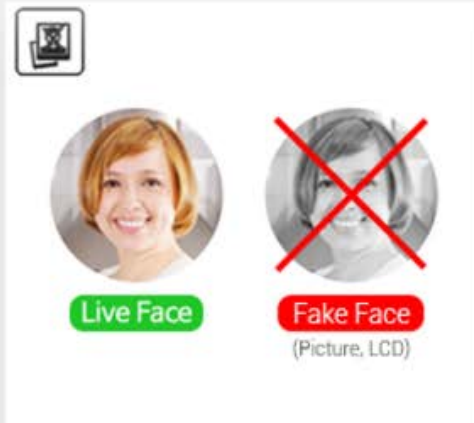

Infra-red based live face detection to prevent spoofing attempts



Multi-band RF reading technology supporting latest RFID standards



High quality face image logs

FaceStation 2

User Interface

Android-based Intuitive GUI

On its wide touchscreen LCD, FaceStation 2 offers industry's most intuitive graphic user interface. Thanks to the latest Android 5.0 OS, FaceStation 2 features latest material design concept to provide extremely easy to use GUI requiring near-zero training for both users and system administrators.



User Interface

3 Step Face Enrollment Process

(1) Registering the front face



(2) Moving the face up and down



(3) Moving the face to the left and right



FaceStation 2

Specification

CONNECTIVITY

Wi-Fi: 802.11 b/g
TCP/IP: Gigabit(10/100/1000 Mbps)
Auto MDI/MDI-X

MICROPHONE

24bit Voice DSP w/ echo cancellation

TOUCHSCREEN LCD

Capacitive 4.0" LCD touchscreen
178° wide viewing angle

MATERIAL

Reinforced(7H) soda-lime glass surface
95%+ transparent clarity
Fingerprint-proof coating

VISUAL CAMERA

CMOS type wide-angle camera
720 x 480 pixels, Diagonal 92.7°
Image log, video phone

INFRA-RED CAMERA

CMOS type IR camera
Diagonal 58°

MULTI-BAND RF READER

- 125kHz EM/HID Prox
- 13.56MHz MIFARE/FeliCa
DESFire(EV1)/iCLASS(SE)/NFC
- 2.4GHz BLE

CPU

1.4GHz Quad-core

MEMORY

8GB Flash + 1GB RAM

GRAPHIC USER INTERFACE

Android(Lollipop) GUI featuring 'material design'
Enhanced enrollment process
Fully customizable with SDK support

IR LED BANK B

Wide angle, outer area

INTERFACES

RS485, Wiegand I/O, relay, TTL, USB2.0

IR LED BANK A

Narrow angle, center area

WEIGHT

548g (1.21lb)

OPERATING TEMPERATURE

-20°C~50 °C (-4°F~122°F)

OPERATING HUMIDITY

0%~80%

POWER

12V DC, 2.5 A



- * Don't share power with lock
- * Refer to manual regarding length of power cord

FaceStation 2

Specification



FaceStation	vs	FaceStation 2
CREDENTIAL		
Infra-red camera	Sensor Type	Infra-red camera
Max 1,000 match/sec	Matching Speed	Max 3,000 match/sec
0.0001%	Minimum FAR	0.00002%
Supported	Live Face Detection	Supported
-	Group Matching	Max 5,000 users
-	Bluetooth	2.4 GHz BLE
-	Multi-RF Reading	Supported
-	NFC	Supported
125 KHz EM/HID Prox	RF Cards	125kHz EM, HID Prox
13.56 MHz MIFARE/DESFire(EV1)/FeliCa/iCLASS(SE)		13.56Mhz MIFARE, MIFARE Plus, DESFire/EV1, FeliCa, iCLASS SE/SR
CAPACITY		
10,000 (1:1), 1,000(1:N)	Max. Users	30,000 (1:1), 3,000(1:N)
5,000	Max. Image Logs	50,000
1,000,000	Max. Text Logs	5,000,000
GENERAL		
667MHz RISC + 900MHz DSP	CPU	1.4 GHz Quad Core
512MB RAM + 4GB Flash	Memory	8GB Flash + 1GB RAM
Windows CE	OS	Android (5.0 Lollipop)
-	Tilt Bracket	Supported
145cm ~ 195 cm	Height Range	145cm ~ 210 cm
26 ea	IR LEDs	140 ea
5,000 lx	Operating Illuminance	25,000 lx
-20° to 40°C	Operating Temperature	-20° to 50°C
CE, FCC, KC, RoHS	Certificates	CE, FCC, KC, RoHS, REACH, WEEE, BT SIG
IEEE 802.11 b/g	Wi-Fi	IEEE 802.11 b/g
USB 1.x	USB	USB 2.0 with microUSB port
Analog, VoIP(voice only)	VoIP	SIP
10/100 Mbps	Ethernet	Gigabit 10/100/1,000 Mbps



Online Resources

- Solutions Page: FAQ
- * *Submitting tickets are for partners only*

<http://support.supremainc.com>

The screenshot shows the Suprema Technical Support portal. At the top left is the Suprema logo and the text "Suprema Technical Support". On the right, it says "Welcome Ethan Kim" and "Agent Portal | Edit profile - Sign out". Below this is a navigation bar with "Home", "Solutions" (highlighted with a red box), "Forums", and "Tickets". Underneath is a search bar with the text "How can we help you today?" and a "SEARCH" button. To the right of the search bar are two links: "+ New support ticket" and "Check ticket status".

Knowledge base

Frequently Asked Questions

Getting Started (1)

 [Note and Links for New Users](#)

API & SDK (2)

 [\[BioStar 2\] SDK and API starter's guide](#)

 [\[BioStar 1\] BioStar 1.92 SDK?](#)

Database & Integration (8)

 [\[BioStar 1\] How to update an existing MS SQL database using DBSetup](#)

 [\[BioStar 2\] BioStar 2.4 Database Table](#)

 [\[BioStar 2\] Changing the root password of Maria DB](#)

 [\[BioStar 2\] BioStar 1 to BioStar 2 Database Migration](#)

 [\[BioStar 1\] Database Table and DB Link Instructions](#)

[» See all 8 articles](#)



Online Resources

- Solutions Page: Forums
- * [Follow to receive updates](#)

<http://support.supremainc.com>

Home Solutions **Forums** Tickets

How can we help you today?

Enter your search term here... **SEARCH**

Community forums [Start a new topic](#)

All about BioStar

Announcements (16)

- [BioStar2 2.4.0.762 Release](#)
Posted by Kate Yu, a month ago ,
Last Reply by Ethan Kim 14 days ago
- [BioStar 1.92 HotFix \(1.9.2.11v\)](#)
Posted by Tim Lee, 2 months ago
- [Upcoming BioStar 2.4.1 New Feature and 2.4...](#)
Posted by Ethan Kim, 6 days ago
- [BioStar 2 Device SDK 2.4.0 Released](#)
Posted by Ethan Kim, 15 days ago
- [Custom solutions are open to all partners](#)
Posted by Tim Lee, a month ago

>> [See all 16 topics](#)

Known Issue (10)

- [Issue about exporting/importing certain fields...](#)
Posted by Hailey Park, 15 days ago

Custom Solution (2)

- [\[BioStar 1\] Increasing Maximum Leave to 500](#)
Posted by Ethan Kim, 5 days ago
- [Smart Card support with HID SEOS and W2](#)
Posted by Tim Lee, a month ago

BioStar1 & BioStar2 Webinar (2)

- [Webinar Slides and Videos](#)
Posted by Ethan Kim, a month ago



Online Resources

- Knowledgebase: System Configuration
- * No login required

<http://kb.supremainc.com>

The screenshot displays the Suprema Knowledge Center interface. At the top left is the Suprema logo and the text "Knowledge Center Training, Technical resources, and more". To the right is a search bar with a magnifying glass icon and a "LOGIN" button. Below the header, a breadcrumb trail reads "Trace: Suprema Knowledge Center > System Design & Dev. > System Configuration". On the right side of the page, there are two tabs: "System Configuration" and "ent:rn_config_main". The main content area features the heading "System Configuration" in large black font, accompanied by a graphic of several colorful cards with icons representing various system features like a fingerprint, a shield, a clock, a gear, and a magnifying glass. On the left sidebar, under "BioStar 2 Training Center", the "System Configuration" link is highlighted with a yellow box. Below this, under "Technical Information", there is a list of document types: Technical Column, White Paper, Application Note, Case Analysis, A&E Specification, FW Compatibility Chart, and Product Comparison.

Any Questions?



Thank You

CREDITS:

Slide 4 icon designed by Madebyoliver from Flaticon

Slide 11 icon designed by Freepik from Flaticon

SUPrema